

# Verdermag Global HP



## GENERAL

Horizontal End-Suction centrifugal pump

Centerline discharge

Mag-drive

Synchronous coupling

Maximum possible temperature: 205 °C

Minimum possible temperature -100 °C

Maximum discharge pressure: Up to 200bar based on design

Slurry: max 5% wt.; size: max. 150 µm

Maximum diameter solids: 0.5 mm

Minimum flow: 10% of maximum efficiency flow

Maximum viscosity: 150cPs (Subject to power limits)

Maximum power transmission: 30kW based on design

## Front cover

- Fabricated or cast in a range of metallic materials to suit project
- Flanges: BS 4504 (ISO 2084-1974) Class PN40, PN64, PN100 or PN160
- BS 1560 (ANSI/ASME B16.5) Class 300, 600, 900 or 1500

## Casing

- Top centerline discharge, self venting
- Fabricated or cast in a range of metallic materials to suit project
- Case mounted directly to pedestal (no feet)
- Flanges: BS 4504 (ISO 2084-1974) Class PN40, PN64, PN100 or PN160
- BS 1560 (ANSI/ASME B16.5) Class 300, 600, 900 or 1500

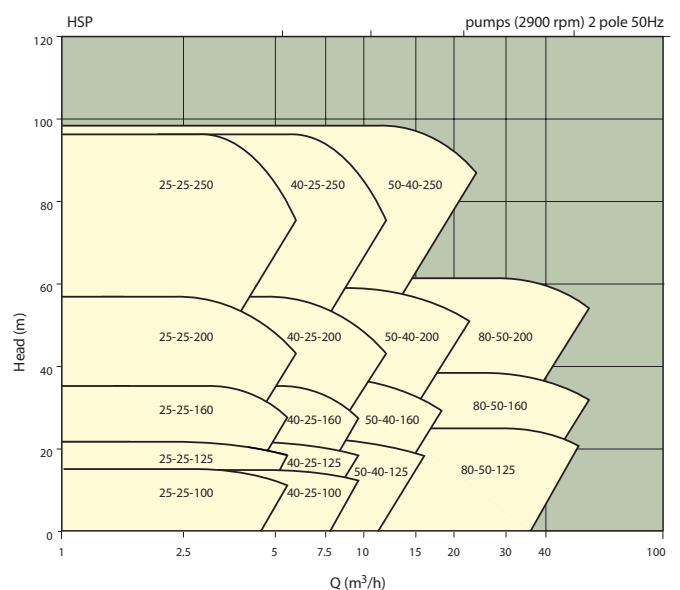
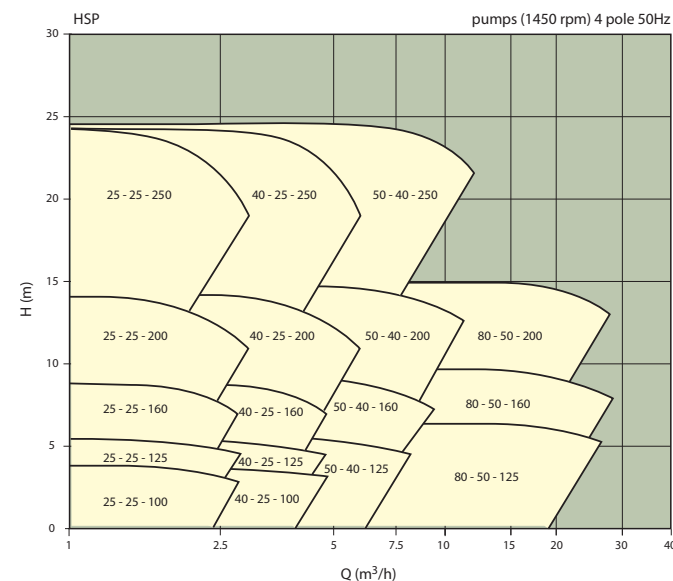
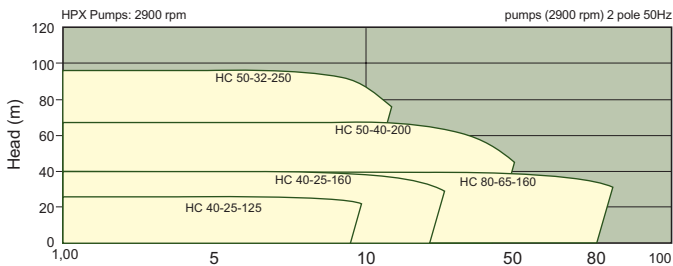

# Verdermag Global HP

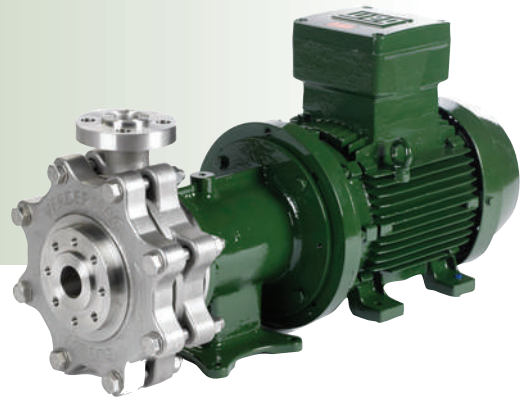

## Impeller

- Closed type
- Standard 316/CF8M construction (other materials available)
- Bored and keyed to suit standard Global pump shafts

## Inner magnet – pump shaft

- Stainless steel 316L internal pump shaft (other materials available)
- Hollow shaft flow induction system
- Magnets fully encapsulated with tough 316L sheath
- Coupled to impeller by key, washer and locking nut
- Machined O-ring grooves, to carry rotating silicon carbide bearing components

## Outer magnet

- Mild steel outer magnet ring with resin filler and protective rings surrounding magnets
- Mounts directly to motor shaft by self centering taper lock adapter and bush

## Containment tube

- Hastelloy/Stainless or Inconel 625 construction as standard (other materials available)
- Separate bearing holder, with flow induction holes for bearing lubrication

## Bearings

- Silica free silicon carbide front and rear bearings fitted as standard
- Bearings are press fit onto elastomers O-rings – allowing:
  - Thermal shock absorption
  - Easy maintenance
- Fluoroscint rear thrust ring supplied as standard on 100/125 frame models – (Full Silica free silicon carbide rear bearings optional)

## Magnet coupling

- Rare Earth Samarium Cobalt high temperature grade magnets
- Synchronous, no slippage, low losses
- Eliminates need for soft starter devices

## Close coupled bracket

- Provides metal to metal fit to casing / backplate
- Central foot mounting for simple installation
- Eliminates flexible coupling, bearing frame and alignment
- Utilises standard IEC motors – To suit frame sizes from 80 - 200
- NEMA available on request

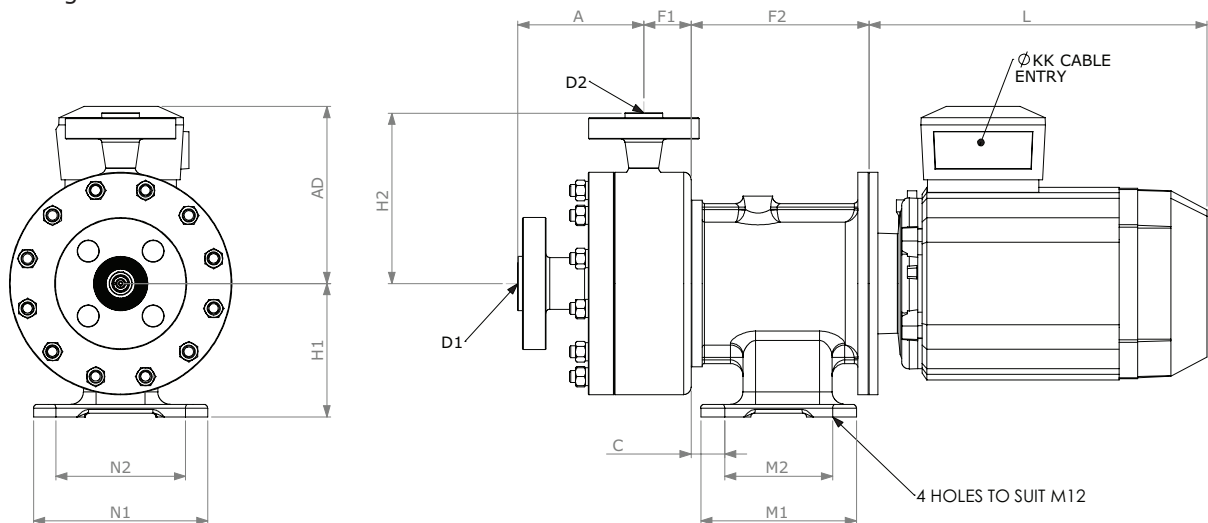

VM\_Global\_Techno\_Rev01\_2012\_UK\_(eu)

Find your local supplier  
at [www.verderglobal.com](http://www.verderglobal.com)

**VERDER**  
passion for pumps